



PRIMO Kn WC-Partition system



PRIMO Kn with special decor at Hotel Adina in Berlin

KEMMLIT For Every Demand

KEMMLIT is the market leader for cubicle systems - made in Germany!
 We at Kemmlit design and construct integrated solutions from washrooms and locker rooms to complete changing room sluices for clean rooms.

The latest production techniques, strict quality control and the use of high quality materials result in products, that meet the highest standards. Taking into account individual needs of the customer, KEMMLIT develops technically and aesthetically outstanding products, tailored to specific spatial conditions.

In the last few years, we have received numerous prizes and awards. Let us introduce our products and our company. Our sales representatives will be there for you to discuss your individual requirements.



PRIMO Kn Overview

KEMMLIT For Every Demand	2
PRIMO Kn A Classic	4
PRIMO Kn Details	11
PRIMO Kn Standard	12
PRIMO Kn Support-Optimised	13
PRIMO Kn Endless Possibilities	14
PRIMO Kn Innovative Handle Bar with LED	18
PRIMO Kn Standard Door Hardware	19
PRIMO Kn Head Rail, Hinges and Legs	20
saniQub The Ingenious Cubicle System	22
saniQub Accessory Choices	23
saniApps Cubicle System Accessories	24
PRIMO Kn Supplementary Products	26
PRIMO Kn Planning Aid	28
saniQub Planning Aid	30
PRIMO Kn Colour Concept	33



PRIMO Kn A Classic

Innovation is a trademark of KEMMLIT. Already in the 1970s, Kemmlit introduced PRIMO - the first HPL sandwiching system world-wide. Since then, the system has been continually further developed and improved. Little by little, construction with foam-filled PVC frames and visible buffer profiles turned into a smooth-surfaced system made of environmentally friendly components.

In 1994, PRIMO first had a frame made of HPL with a polystyrene core. Then the award-winning Get-Fresh concept in the end of the 1990s, added more improvements such as full-height systems and integrated light elements. Now PRIMO Kn is the next level of this unique success story. Completely smooth-surfaced, with aluminium frames and an element thickness of 42mm, the system presents a never-before-seen quality.

The innovative partition saniQub and numerous accessory elements ensure maximum convenience, while the comprehensive colour palette practically meets every colour preference. And all this, within very short delivery times. PRIMO Kn impresses customers and architects from the outset.





PRIMO Kn with doors in wooden decor





PRIMO Kn in combination with the saniQub cubicle system





*PRIMO Kn in combination with the saniQub cubicle system
in the Kaspar Schulz factory for brewery machines in Bamberg.*

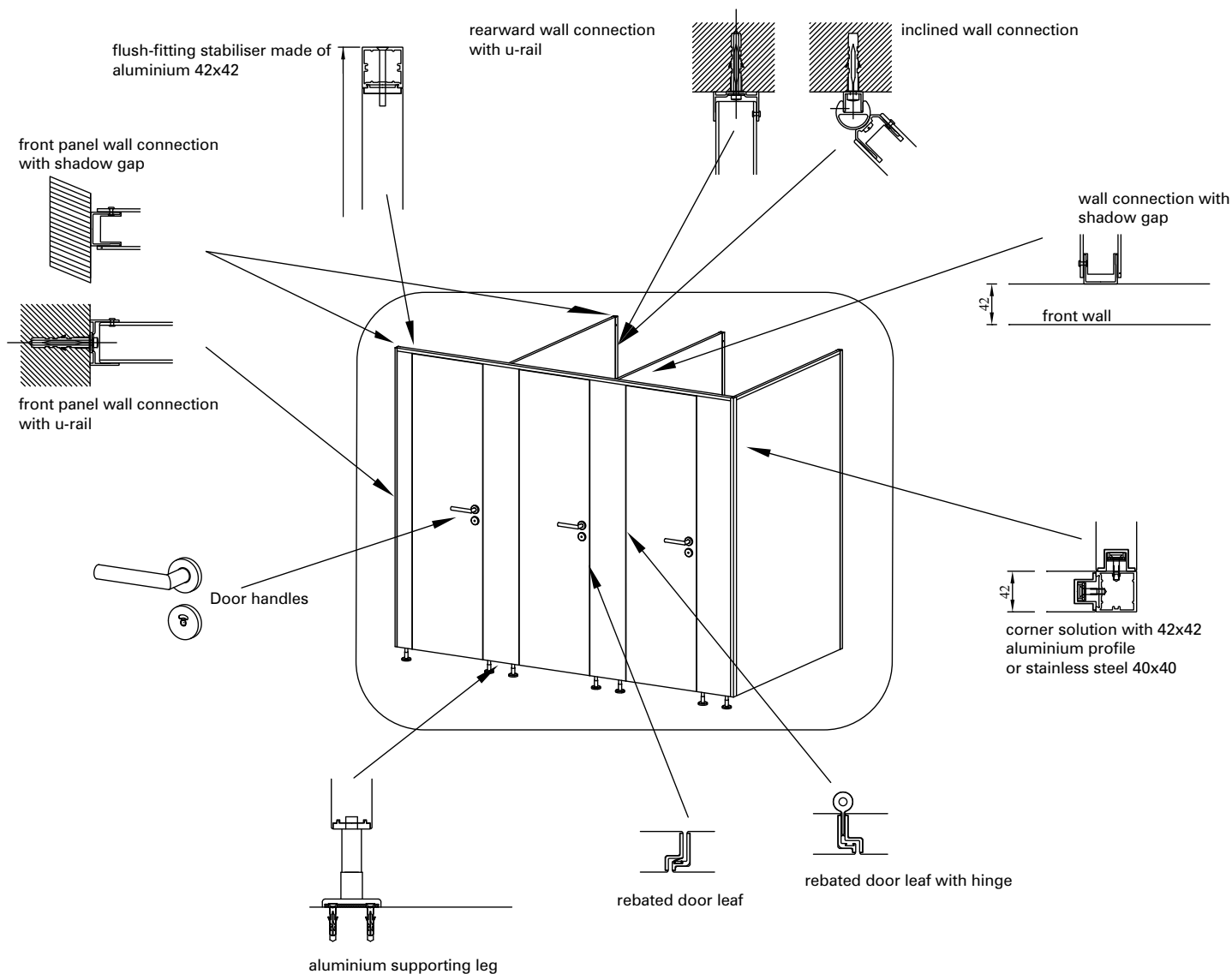

PRIMO Kn Details

PRIMO Kn meets the highest requirements concerning aesthetics and functionality. The system is smooth-surfaced and rebated. Doors and walls are made of a 42 mm thick composite elements with internal aluminium frames for maximum torsion resistance and longevity. A special protective layer on the HPL-surface increases the scratch and abrasion resistance.

PRIMO Kn is suitable for wet and dry rooms. In order to withstand even intense wear, the system was developed with a substantial three-roller edge hinge with a stainless steel axis. All profiles are made of high-quality anodised aluminium.



PRIMO Kn Standard

The PRIMO Kn standard version is designed with legs and stabilisers in the front panel. With an underpanel floor clearance of 150 mm, with an adjustable range of +/- 20 mm. Legs are available in a choice of aluminium or stainless steel, and are firmly screwed onto the front elements using a M12 thread.

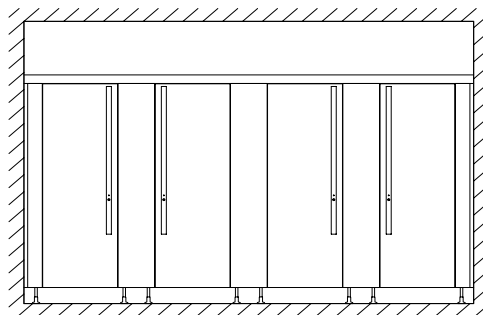



PRIMO Kn Support-Optimised

Alternatively PRIMO Kn is available in a support-optimised version with legs integrated only in the partition walls. Thus giving the system not only a modern appearance and airiness, but also facilitating cleaning at the same time. It is also possible to set back the stabiliser upon request, for an overall floating appearance.

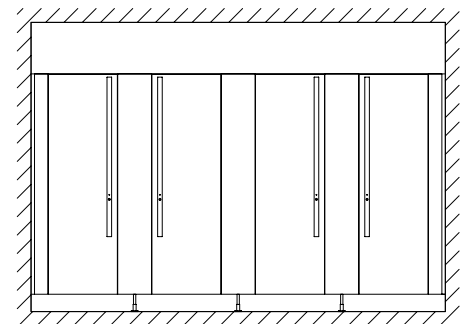



PRIMO Kn Endless Possibilities

In addition to the standard option, PRIMO Kn also comes in a suspended version with a carrier section or in a floor-to-ceiling version or with transoms. In the suspended version, the carrier section is fastened to the masonry wall or supported by columns. All front wall panels are suspended from the carrier section and invisibly screw-connected so that there is no need to drill holes in the floor.

The floor-to-ceiling solution offers maximum privacy because the doors, front panels and partitions are installed flush without clearance. For complete privacy from floor to ceiling. Additionally the design can be tailored to individual needs with transom panels. All panels are available in the KEMMLIT standard colours. Custom colour solutions, customised digital prints or PRIMO BiColor (different colors for front and backside of the panels) are also available upon request.

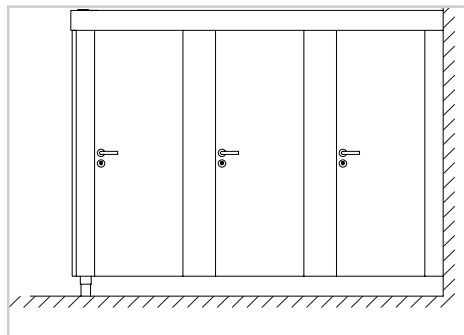

Suspended design without feet with
carrier section 50 x 150 mm

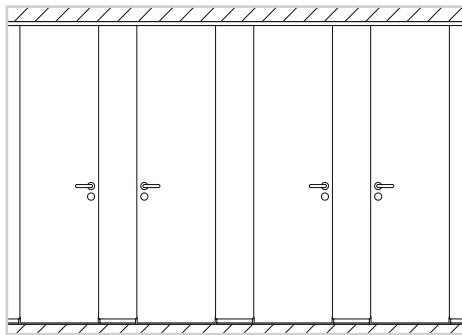

Floor-to-ceiling flush for maximum
privacy, floor-to-ceiling doors or with
door transoms



*PRIMO Kn floor-to-ceiling with individual digital print
at the Gymnasium Johanneum in Herborn*

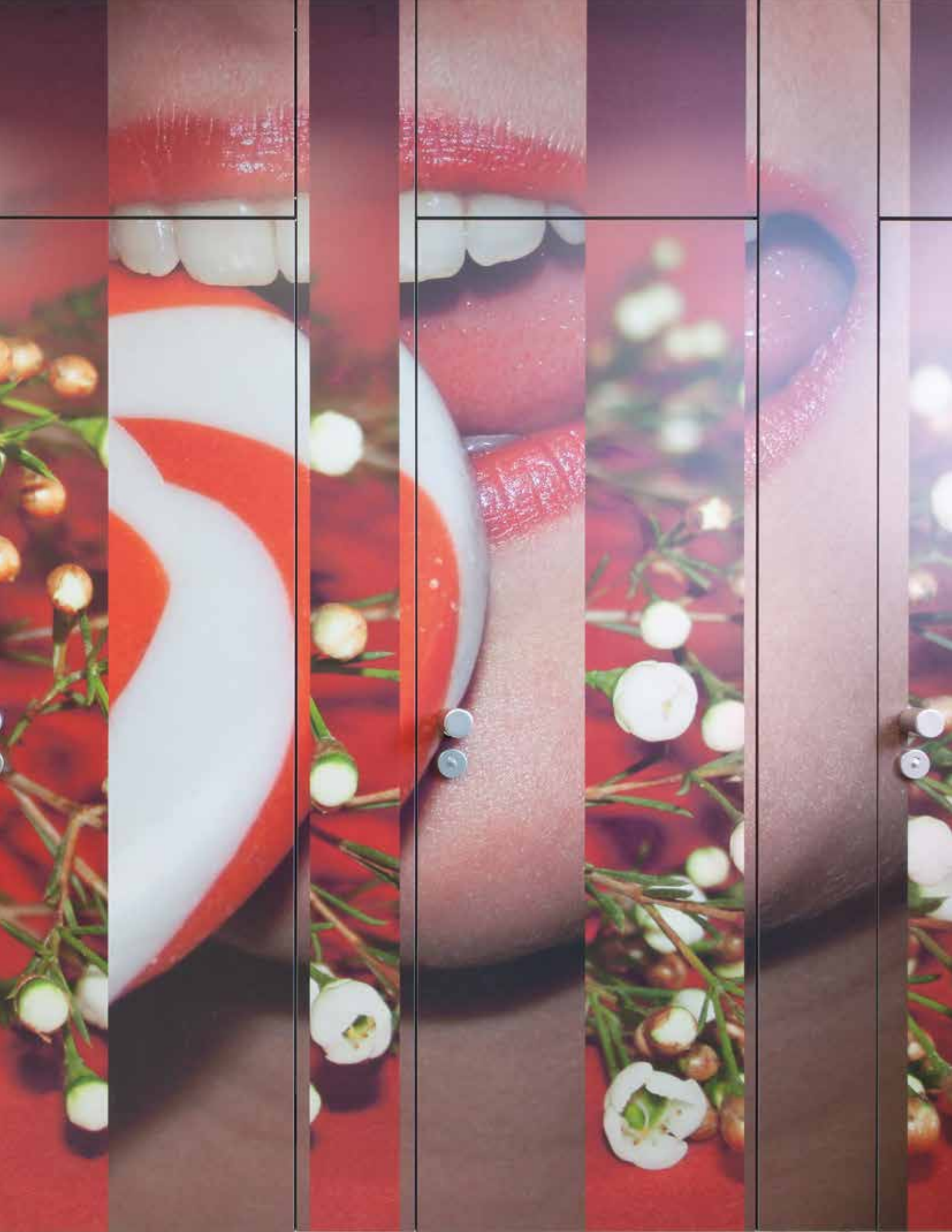



PRIMO Kn Innovative Handle Bar with LED

The innovative KEMMLIT handle bar with integrated lock and an eye-catching LED display offers you an exclusive alternative to the classic handle sets. The LED display is flush integrated into the handle bar and coupled with the lock on the inside of the door. As soon as the door is locked, it is illuminated red.

If the door is open, it remains unlit. A simple metal square is integrated in the handle bar as an emergency opening from the outside.

The handle bar is made of high-quality anodised aluminium and is available in four lengths, S (430 mm), M (1165 mm), L (1300 mm) and XL (1565 mm).

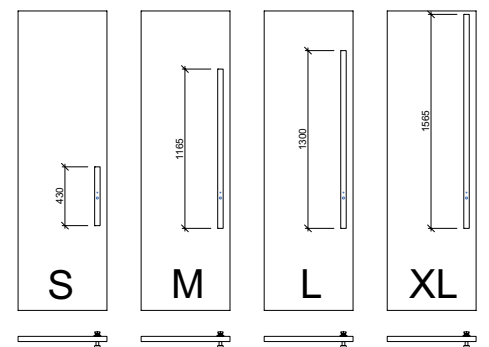



PRIMO Kn Standard Door Hardware

L-handles are available in anodised aluminium or in a stainless steel, matt or satin-finish. They come with an indicator and metal square for emergency release.

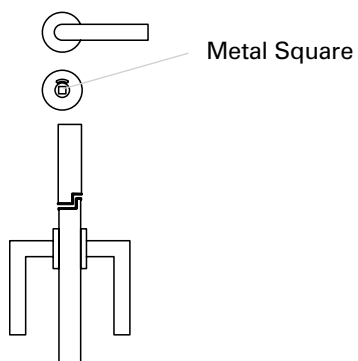

U-shaped safety handles are available in coloured nylon, aluminium or stainless steel. They come with an indicator and metal square for emergency release.

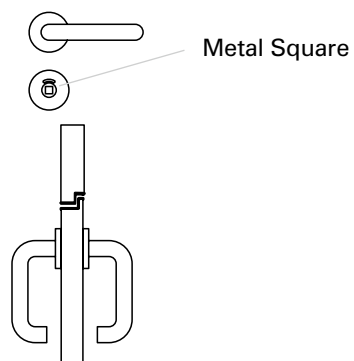

Knobs are available in nylon, aluminium or stainless steel. They come with an indicator and metal square for emergency release.

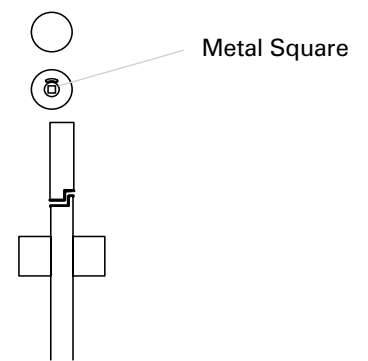



PRIMO Kn Head Rails, Hinges and Legs



Clamping U-profile made of natural anodised or powder-coated aluminium



Alternative: shadow gap detail with natural anodised aluminium profile



Stabiliser made of natural anodised aluminium, 42 x 42 mm, above the front panel or set back



Three-roller edge hinge by KEMMLIT, durable, maintenance free, non-detachable, fastened with six screws



Quality aluminium foot with aluminium covering rosette, 150 mm floor clearance, infinitely adjustable



Screw connection at leg with solid stainless steel foot plate



saniQub® The Ingenious Cubicle System

Our innovative saniQub cubicle system offers more than just a separation of two cubicles. All the sanitary accessories can be smoothly integrated into the high-quality composite element. Thus it results in an aesthetically perfect overall appearance. The partition walls are equipped according to your individual requests and delivered pre-assembled.

saniQub is a custom-made solution, which does not require any subsequent assembly of accessory elements. Thus saving time during installation. saniQub consists of 3 mm solid HPL boards with solid aluminium frames which are filled with polystyrene. Optionally each wall can be equipped with accessory elements on both sides of the partition wall. In addition to the accessory elements, it can be further individualised by choosing a custom colour scheme.



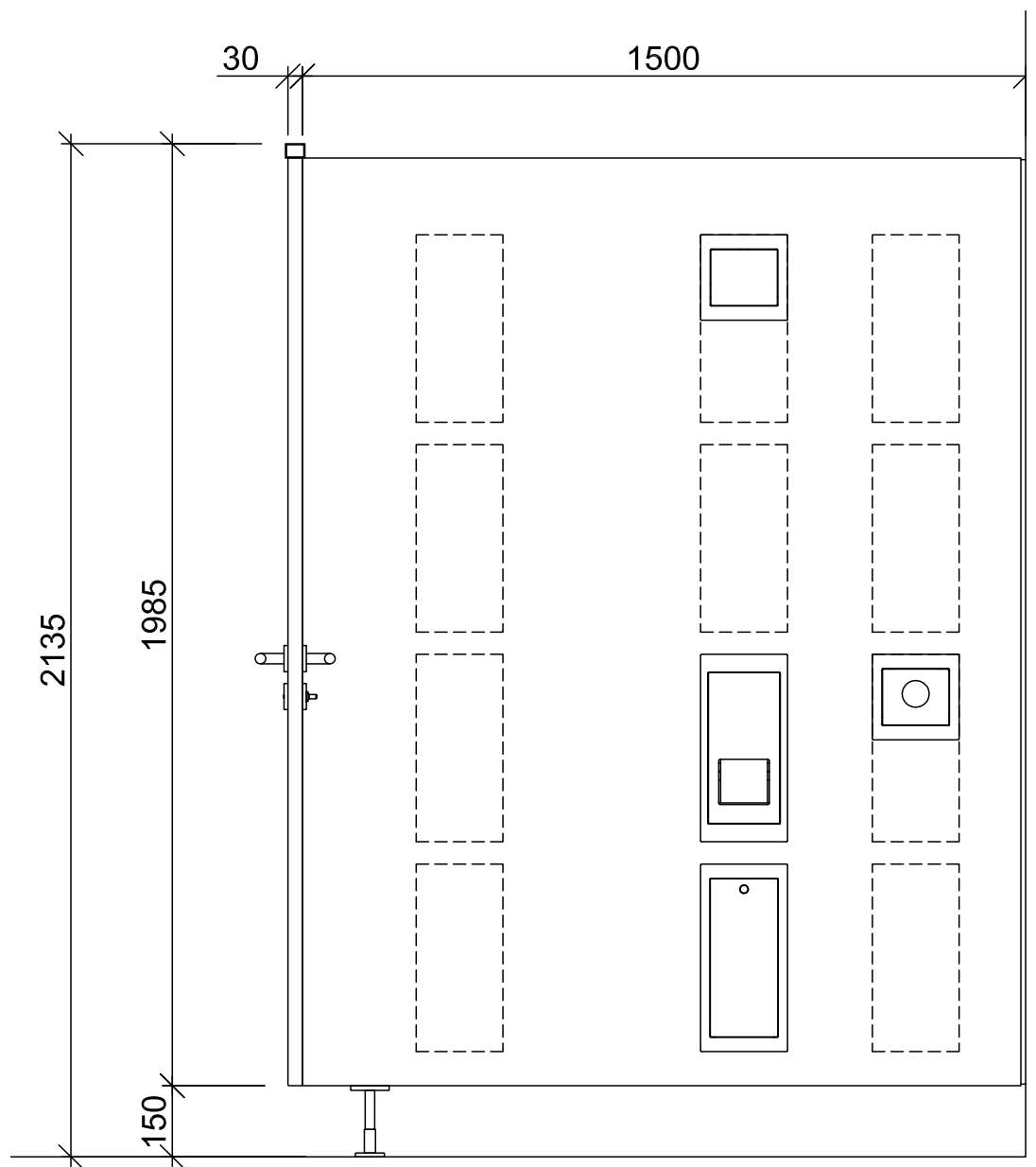

saniQub[®] Accessory Choices

saniQub flexibly meets your wishes and requirements. The depth of the partition wall ranges from 1250 mm to 1600 mm, the floor clearance from 0 mm to 180 mm. The system height can be selected freely from 2000 mm to 2400 mm (full height floor-to-ceiling design is available upon request).

A comprehensive selection of high-quality accessory elements, the so-called saniApps, practically meet all needs. The choices range from standard elements such as toilet paper holders and brush set to stainless steel mirrors, fragrance dispensers and more. Even completely pre-configured systems are available.



saniApps® Cubicle System Accessories

saniApps can be flexibly planned according to your individual needs. In addition to classical saniApp elements such as toilet paper holders, toilet brush sets and waste bins, it is also possible to include fragrance and or hygiene bag dispensers, and mirrors.



SystemApp M



SystemApp L

Alternatively, you can order saniApps as pre-configured system elements in two different designs: SystemApp M made of stainless steel with an elegant, brushed surface.

Dimensions: 390 x 695 mm.

Elements: a double roll holder for commercial toilet paper, a toilet brush set and a waste bin with hygiene bag compartment.

Or SystemApp L made of stainless steel with an elegant, brushed surface. Dimensions: 390 x 900 mm.

Elements: a saniApp double roll holder for commercial toilet paper, a fragrance dispenser, a toilet brush set, a waste bin with hygiene bag compartment as well as a storage bin and a disinfectant dispenser.



Urinal screens made of glass, HPL or wood-based material



Sanitary facility accessories made of nylon or aluminium



Shelves made of nylon



Locker systems

PRIMO Kn Supplementary Products



Mädchen

*PRIMO Kn floor-to-ceiling flush
in the Ludwig-Uhland school in Leinfelden-Echterdingen*

PRIMO Kn Planning Aid

	Standard	Options at Additional Charge	
WC cubicles:	<ul style="list-style-type: none"> • WC-cubicle system with feet and stabilisers integrated in the front panel 	<ul style="list-style-type: none"> • Optimised support WC cubicle (feet set back, only in series systems) • WC cubicle without floor clearance 	<ul style="list-style-type: none"> • Suspended WC cubicle (feet and stabiliser set back) • WC cubicle floor-to-ceiling
Single niche cubicles:	<ul style="list-style-type: none"> • Feet and stabilisers integrated in the front (stabiliser cannot be set back) 	<ul style="list-style-type: none"> • Vestibule partition between WC room and washroom, also available floor-to-ceiling 	
Unit height:	<ul style="list-style-type: none"> • 2000 mm including 150 mm floor clearance (+/- 20 mm) • 2135 mm including 150 mm floor clearance (+/- 20 mm) 	<ul style="list-style-type: none"> • Special heights on request, • Max. 2800 mm for floor-to-ceiling systems. • Wood decor and special colours available on request. • Floor-to-ceiling doors possible 	
Front wall section:	<ul style="list-style-type: none"> • Panel widths range from 140 mm to 1580 mm per element and can be individually planned 		
Cubicle depth:	<ul style="list-style-type: none"> • Up to 1580 mm 	<ul style="list-style-type: none"> • Partition panels 1581 mm or larger are divided by a tongue-and-groove joint which is supported by an additional foot and stabiliser. In Floor-to-ceiling systems partition panels are divided if 1200 mm or larger. 	
Cubicle Door/Wall material:	<ul style="list-style-type: none"> • 42 mm HPL composite element, 3 mm HPL cover on either side, core made of polystyrene 		
Edge protection:	<ul style="list-style-type: none"> • Flush-mounted, solid, anodised aluminium edge (E6EV1) 		
Door swing:	<ul style="list-style-type: none"> • rebated doors can be opened inwards and outwards within a front. Optionally doors are available with a recessed rubber strip for silent closure 		
Door height/clearance:	<ul style="list-style-type: none"> • For a system unit height of 2135 mm the passage clearance height is 2093 mm 	<ul style="list-style-type: none"> • Up to max. 2760 mm for floor-to-ceiling doors • Special door widths available on request 	<ul style="list-style-type: none"> • For lower doors: door transom and 40 mm ceiling connection profile
Door widths:	<ul style="list-style-type: none"> • 570 mm (nominal dimension) • 650 mm (nominal dimension) standard • 750 mm (nominal dimension) • 980 mm (nominal dimension) 		
Head rail:	<ul style="list-style-type: none"> • 42 x 42 mm, anodised aluminium profile, (E6EV1) 	<ul style="list-style-type: none"> • 40 x 30 mm in the front panel, stainless steel • 40 x 30 mm when suspended, stainless steel 	<ul style="list-style-type: none"> • 40 x 30 mm when suspended, aluminium
Ceiling connection:		<ul style="list-style-type: none"> • Ceiling connection with overlapping aluminium profile 40 x 4 mm (in suspended ceilings, stable inserts required) 	
Feet/ground connection:	<ul style="list-style-type: none"> • Anodised aluminium foot with a stainless steel foot plate and aluminium covering rosette, up to 150 mm floor clearance 	<ul style="list-style-type: none"> • Anodised aluminium foot with stainless steel foot plate and aluminium covering rosette, infinitely adjustable from 80 - 215 mm floor clearance • Without floor clearance: aluminium profile (shadow gap) and ventilation below the door via a 30 mm gap 	<ul style="list-style-type: none"> • Stainless steel foot with stainless steel covering rosette, infinitely adjustable from 80 - 215 mm floor clearance • Adhesive feet (starting at 80 mm floor clearance) not possible in support-optimised systems

Our toilet partitions for sanitary spaces are made of 42 mm solid HPL composite elements with a smooth-surfaced, rebated door leaf and aluminium frames. They are designed for wet and dry rooms as well as for sanitary rooms with high demands on appearance, stability and design variety.

Advantages of the system are the classic, high-quality appearance, a completely smooth surface, rebated door leaves, floor-to-ceiling walls and floor-to-ceiling doors without gaps, as well as the high-quality surface made of HPL. Solid fittings and a construction made of 42 mm solid HPL composite elements result in maximum stability and durability.

The water-proof HPL material can be easily cleaned and is excellently suited for the use in wet rooms. Series systems and single niche cubicles can be designed completely freely. A floor-to-ceiling flush toilet cubicle is also possible.

Standard
Options at Additional Charge

Wall connection:	<ul style="list-style-type: none"> • U-profile, anodised aluminium, or powder coated finish 	<ul style="list-style-type: none"> • U-profile, aluminium 	<ul style="list-style-type: none"> • Shadow gap with anodised aluminium profile.
Edge connection for corner cubicles:	<ul style="list-style-type: none"> • Flush mounted corner rod made of anodised aluminium or powder-coated (42 x 42 bb) finish 	<ul style="list-style-type: none"> • Flush mounted corner rod made of stainless steel (40 x 40 mm) 	
Angular wall connection:		<ul style="list-style-type: none"> • Inclined wall connection with internal U-rail, anodised aluminium 	
Angular pilaster:		<ul style="list-style-type: none"> • Made of anodised aluminium profiles, with internal U-rail 	
Hinges:	<ul style="list-style-type: none"> • Three-roller edge hinges made of aluminium (145 mm) with stainless steel pin, screwed 6 times 	<ul style="list-style-type: none"> • Three-roller edge spring hinge made of aluminium of 145 mm) with stainless steel pin • Three-roller edge spring hinge made of stainless steel (145 mm) 	<ul style="list-style-type: none"> • Three-roller edge hinge made stainless steel (145 mm) • Concealed hinge
finger protection:		<ul style="list-style-type: none"> • Aluminium safety tube on the hinge side 	
Handle/Door lock:	<ul style="list-style-type: none"> • U-shaped nylon handle and turning lock made of nylon with square emergency lock, release locking status visible inside and outside 	<ul style="list-style-type: none"> • Aluminium L-shaped handle • Aluminium U-shaped handle • Stainless steel L-shaped handle • Stainless steel U-shaped handle 	<ul style="list-style-type: none"> • Turning lock made of aluminium • Turning lock made of stainless steel • Special hardware on request
Pulls and knobs:		<ul style="list-style-type: none"> • knobs made of nylon • knobs made of stainless steel 	<ul style="list-style-type: none"> • knobs made of aluminium
Handlebar:		<ul style="list-style-type: none"> • Handle bar made of aluminium in four lengths S (430 mm), M (1165 mm), L (1300 mm), XL (1565 mm) with LED 'Occupied' display, alternative with mechanical 'Occupied' display 	
Handle plate:		<ul style="list-style-type: none"> • Offset handle plate 	
Locks:	<ul style="list-style-type: none"> • 2-bolt lock with metal hinge and silent lock 	<ul style="list-style-type: none"> • 1-bolt lock 	
Other special solutions		<ul style="list-style-type: none"> • Sliding doors • saniQub • Urinal wall 13 mm • Screening walls • Disabled cubicle 	<ul style="list-style-type: none"> • Privacy curtain • Individual print • BiColor • Surface anti-bacterial surface coating
Certification mark:	<ul style="list-style-type: none"> • TÜV-tested and GS-certified 		

Subject to technical change without notice 02/16

saniQub Planning Aid

	Standard	Alternative Option
Plan:	<ul style="list-style-type: none"> • Only available as partition wall in series system, not as door front 	
Cubicle depth:	<ul style="list-style-type: none"> • Standard 1500 mm, min. 1250 mm, max. 1600 mm 	
Unit height:	<ul style="list-style-type: none"> • 2000 - 2400 mm 	<ul style="list-style-type: none"> • Special heights and floor-to-ceiling height upon request
Wall element:	<ul style="list-style-type: none"> • 156 mm solid composite construction with 3 mm cover made of HPL (high pressure laminate), solid polystyrene core and a circumferential aluminium frame profile 	
Foot construction:	<ul style="list-style-type: none"> • Anodised aluminium foot with 80 - 180 mm floor clearance and aluminium covering rosette 	<ul style="list-style-type: none"> • Without floor clearance, with aluminium profile
Wall connection, without primary walling:	<ul style="list-style-type: none"> • Shadow gap profile made of anodised aluminium, gap approx. 10 mm 	
Wall connection, with primary walling:		<ul style="list-style-type: none"> • With parapet panels and shadow gaps
Designs:	<ul style="list-style-type: none"> • Optimised support system with recessed leg, stabiliser above the front panel 	<ul style="list-style-type: none"> • Suspended system with set back feet and stabiliser • Feet and stabiliser integrated in the front panel
Vestibule partition:		<ul style="list-style-type: none"> • Possible in individual cases following consultation
Screening walls:		<ul style="list-style-type: none"> • Possible in individual cases following consultation
Wall accessories saniApps:		
Double toilet paper roll holder:	<ul style="list-style-type: none"> • Made of stainless steel with an elegant, brushed surface, dimensions 395 x 180 mm, perfectly suited for two KEMMLIT longlife toilet paper rolls (900-sheet roll), but also suitable for any standard toilet paper rolls. Integrated space for spare roll, holder comes with cylinder lock. 	
Waste bins:	<ul style="list-style-type: none"> • Made of stainless steel with an elegant, brushed surface, knob for easy use, capacity approx. 5 l, dimensions 395 x 180 mm 	
Toilet brush set:	<ul style="list-style-type: none"> • Made of stainless steel with an elegant, brushed surface, dimensions 395 x 180 mm, for toilet brushes with a brush head diameter of approx. 8.5 cm 	
Hygiene bag dispenser:	<ul style="list-style-type: none"> • For plastic bags, with elegant, brushed surface, dimensions 180 x 180 mm 	
Fragrance dispenser:	<ul style="list-style-type: none"> • Made of stainless steel with an elegant, brushed surface, dimensions 180 x 180 mm, with cylinder lock, fragrance is dispersed through air holes on the surface and is spread into the room by moving the cubicle door 	
Mirror:	<ul style="list-style-type: none"> • Made of stainless steel, with mirror polished surface dimensions 395 x 180 mm 	<ul style="list-style-type: none"> • Made of stainless steel, with mirror polished surface dimensions 830 x 180 mm
Doorstop hook:	<ul style="list-style-type: none"> • Made of stainless steel with an elegant, brushed surface, dimensions: 105 mm long, diameter of the covering rosette 60 mm, diameter of hook 15 mm 	

Standard

Wall accessory SystemApp M:	<ul style="list-style-type: none">• System element made of stainless steel with an elegant, brushed surface, dimensions 390 x 695 mm, consisting of: double roll holder for commercial toilet paper, fragrance dispenser, toilet brush set made of stainless steel with brushed surface, waste bin with hygiene bag compartment	
Wall accessory SystemApp L:	<ul style="list-style-type: none">• System element made of stainless steel with an elegant, brushed surface, dimensions 390 x 900 mm, consisting of: double roll holder for commercial toilet paper, fragrance dispenser, toilet brush set made of stainless steel with brushed surface, waste bin with hygiene bag compartment, storage compartment and disinfectant dispenser	

Subject to technical change without notice 02/16



PRIMO Kn Colour Concept

PRIMO Kn is characterised by a large number of colours and combination possibilities. The selection is almost limitless. In addition to the standard colours shown, the walls and doors can be designed with PRIMO BiColor (different colours on either side).

Even special colours and individual digital prints are possible at any time on request. The PRIMO Kn colour concept also applies to the saniQub cubicle system and of course, perfectly matches all other KEMMLIT products.

Walls and doors:

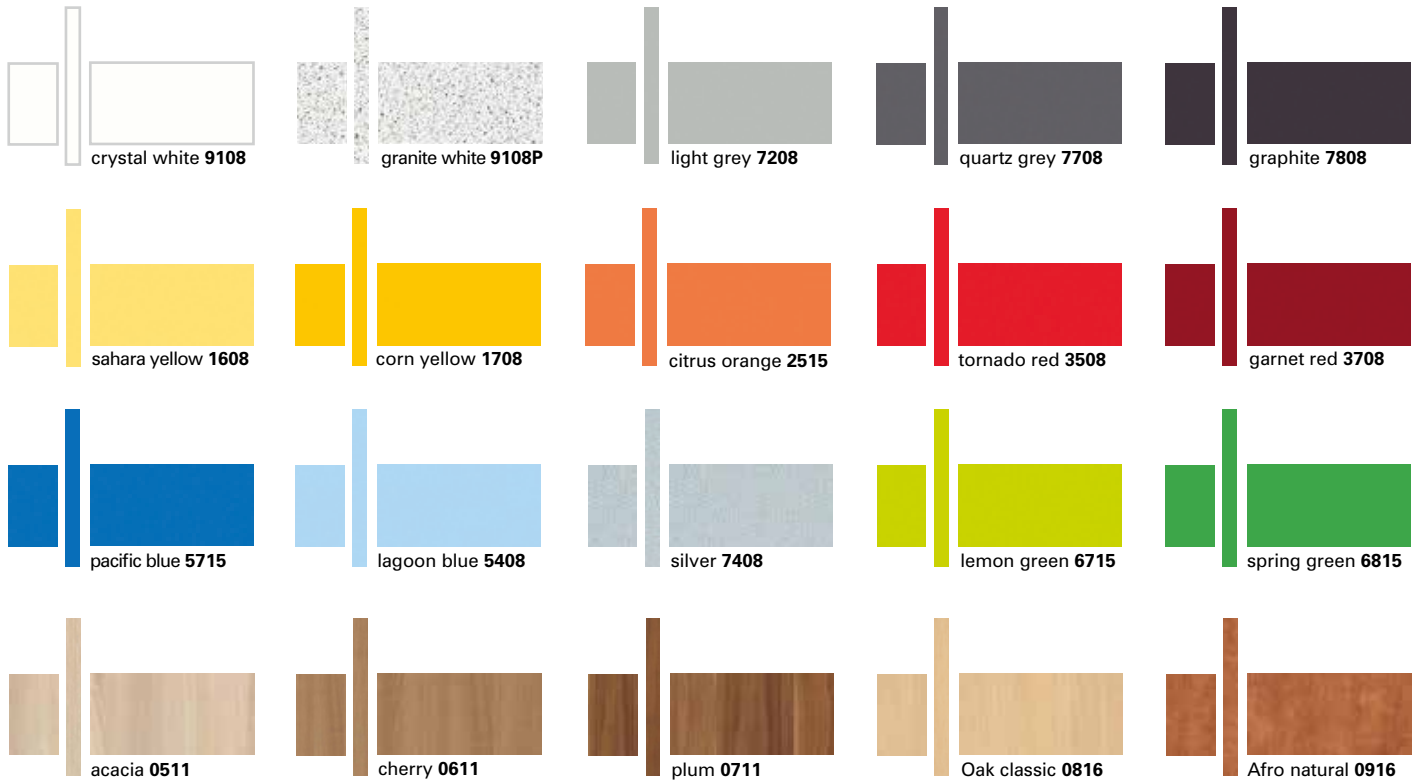

Head rail*, hinges, furniture, legs and accessories:

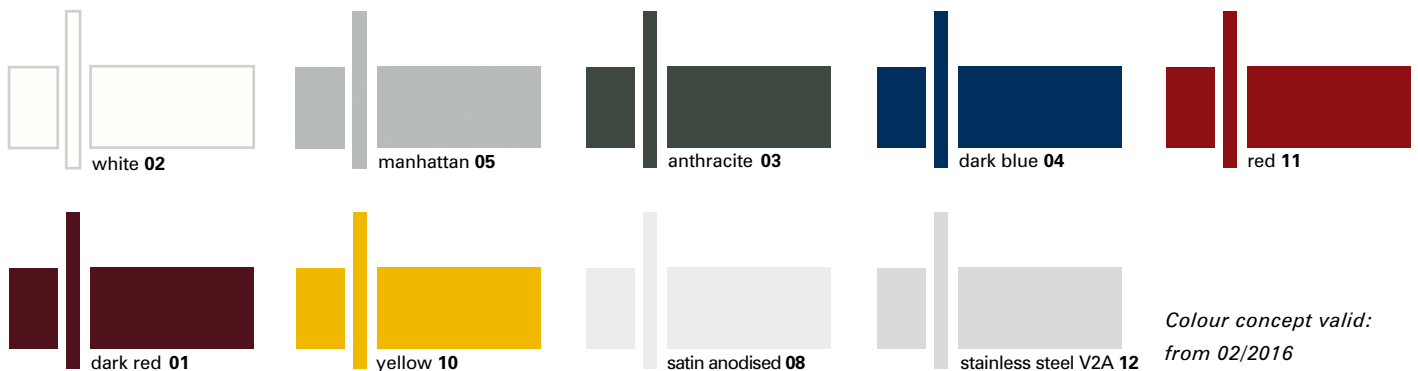

Colour concept valid:
from 02/2016

* Profiles only anodised in natural colour 08 or stainless steel V2A 12

Please note that the depicted colours can vary slightly from the original due to typographical reasons. We would be pleased to provide you with actual samples.



www.kemmlit.de



KEMMLIT-Bauelemente GmbH · Maltschachstraße 37 · D-72144 Dusslingen

Tel.: +49 (0) 7072 /1 31-0 · info@kemmlit.de · www.kemmlit.de